

Existing Condition Vertical Termination

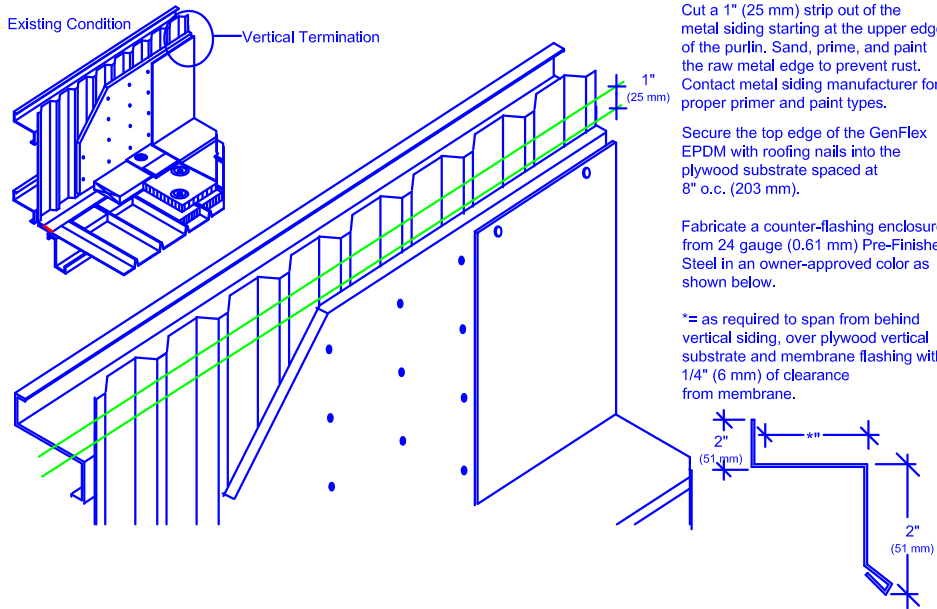

Cut a 1" (25 mm) strip out of the metal siding starting at the upper edge of the purlin. Sand, prime, and paint the raw metal edge to prevent rust. Contact metal siding manufacturer for proper primer and paint types.

Secure the top edge of the GenFlex EPDM with roofing nails into the plywood substrate spaced at 8" o.c. (203 mm).

Fabricate a counter-flashing enclosure from 24 gauge (0.61 mm) Pre-Finished Steel in an owner-approved color as shown below.

\*= as required to span from behind vertical siding, over plywood vertical substrate and membrane flashing with 1/4" (6 mm) of clearance from membrane.

Wood nailer(s) as required to provide an anchor point for the loose siding cut in step 1" (25 mm) above and to secure the counter-flashing to. Fasten to purlin as required to achieve 200 lb (890 N) of pullout resistance per linear foot but with fasteners spaced no more than 24" (610 mm) apart.

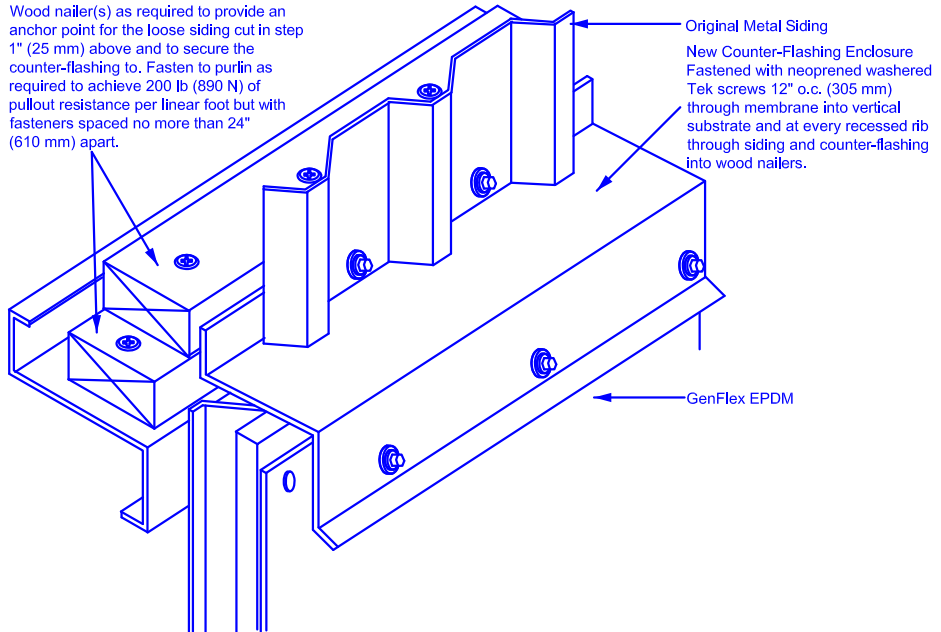

Original Metal Siding  
New Counter-Flashing Enclosure Fastened with neoprened washered Tek screws 12" o.c. (305 mm) through membrane into vertical substrate and at every recessed rib through siding and counter-flashing into wood nailers.

GenFlex EPDM

MAXIMUM WARRANTY: **20 Years**

ISSUE / REVISION DATE:  
6-25-2015  
NOT TO SCALE

DETAIL NO.  
**EMR-1.13**



**Metal Roof to Metal Siding - Vertical Termination and Counter-Flashing**

EPDM Systems

ACCEPTABLE SYSTEMS:  
All Systems