

1. All parapet walls and roof curbs must be suitable for flashing, i.e. clean, tight, smooth, no cracks, etc.
2. All wood nailers to be approved material. Attachment of wood nailer to be accomplished by using fasteners providing no less than 125 lb (556.03 N) of pullout, and fasteners shall be spaced no greater than 24" (609.60 mm) o.c.
3. When cured flashing is used on wall or curb flashing, vertical seams must be stripped-in at the base of angle change with a 6" (152.40 mm) strip of FlexFlash E, or 7" (177.80 mm) Peel & Stick Flashing. See Detail E-3.01
4. Metal coping cap, expansion joint, and edge details are typical only. All metalwork should be installed to sheet metal codes (SMACNA). Clean all metal prior to installation of GenFlex materials.

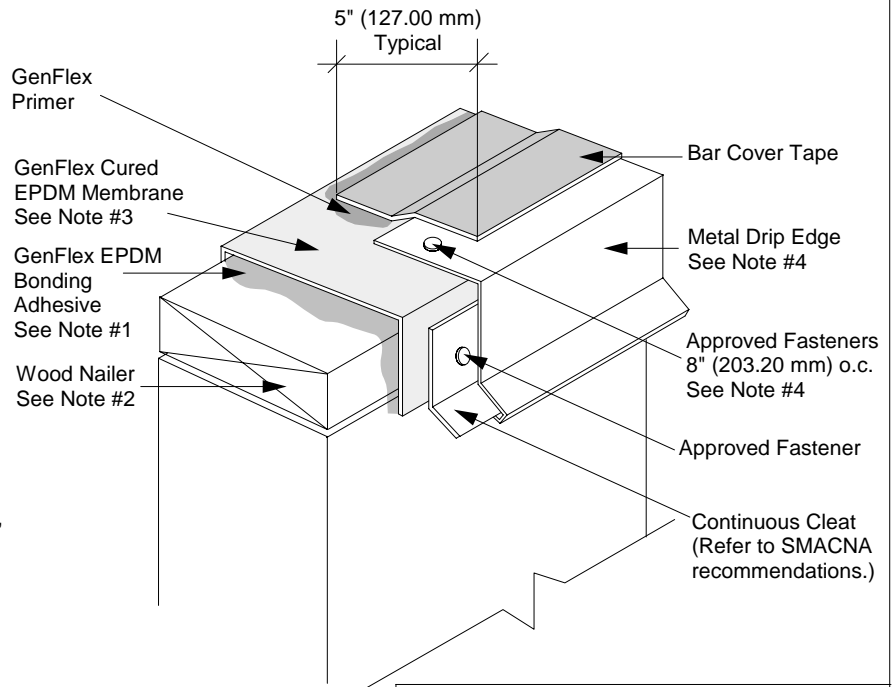

**GenFlex**  
Roofing Systems 10/06

**Parapet Wall  
with Metal Edge**

**Detail #: E-1.05**

**EPDM Systems**