

Alternate securement method.

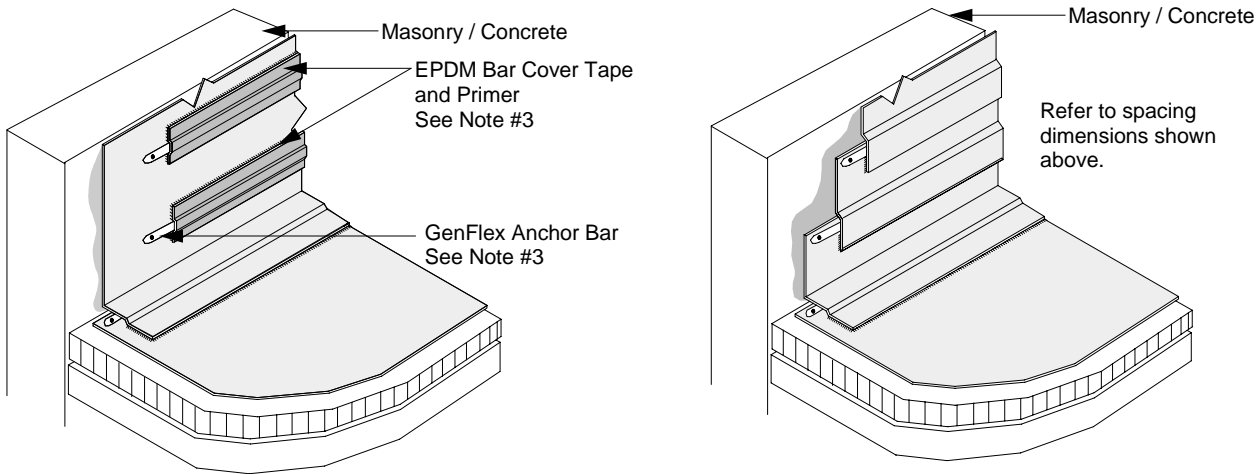

1. Intermediate securement is required on all vertical fully adhered flashings in excess of 48" (1.22 m) o.c. For applications greater than 48" (1.22 m), but less than 8' (2.44 m), install the intermediate securement along a horizontal line halfway between the top of the wall or parapet and the finished roof surface.
2. Plywood or OSB securement to metal studs must be in accordance with industry standards and capable of preventing the plywood or OSB from warping or bowing. Special care should be taken to ensure tight and flush joints in the sheathing material. Securement must be achieved with an appropriate screw-type fastener in order to mitigate the possibility of fastener back-out.
3. Intermediate securement may be achieved with an inner-seam anchor bar as shown or by the application of the anchor bar through the flashing membrane. If anchor bar is secured through the flashing membrane, it must be stripped-in with Bar Cover Tape, and all TOP edges of Bar Cover Tape must be caulked with EPDM Edge Caulk.
4. GenFlex Anchor Bar intermediate securement will be secured at 12" (304.80 mm) o.c. into the plywood or OSB substrate with #14 or #15 GenFlex fasteners.

For metal stud mounted substrates other than plywood or OSB, see Detail E-3.02B.



Intermediate Securement Into Structural Substrate	Detail #: E-3.02A	EPDM Systems
--	--------------------------	---------------------