

NOTE:

1. REFER TO THE GENFLEX WEBSITE FOR THE MOST CURRENT INFORMATION.
2. PRIME ALL SURFACES WITH APPROVED PRIMER.
3. ONE-PART POURABLE SEALER SHOULD BE APPLIED WITH A BOTTOM COAT OF 30 MIL WET THICKNESS AND A TOP COAT OF 30 MIL WET THICKNESS.
4. FOR MECHANICALLY-ATTACHED SYSTEMS WHERE MEMBRANE FASTENERS ARE AT THE BASE OF A WALL, CURB, OR PENETRATION, THE LIQUID FLASHING MEMBRANE (INCLUDING FABRIC) MUST EXTEND 3" (76 mm) PAST THE EDGE OF THE FASTENERS/PLATES.

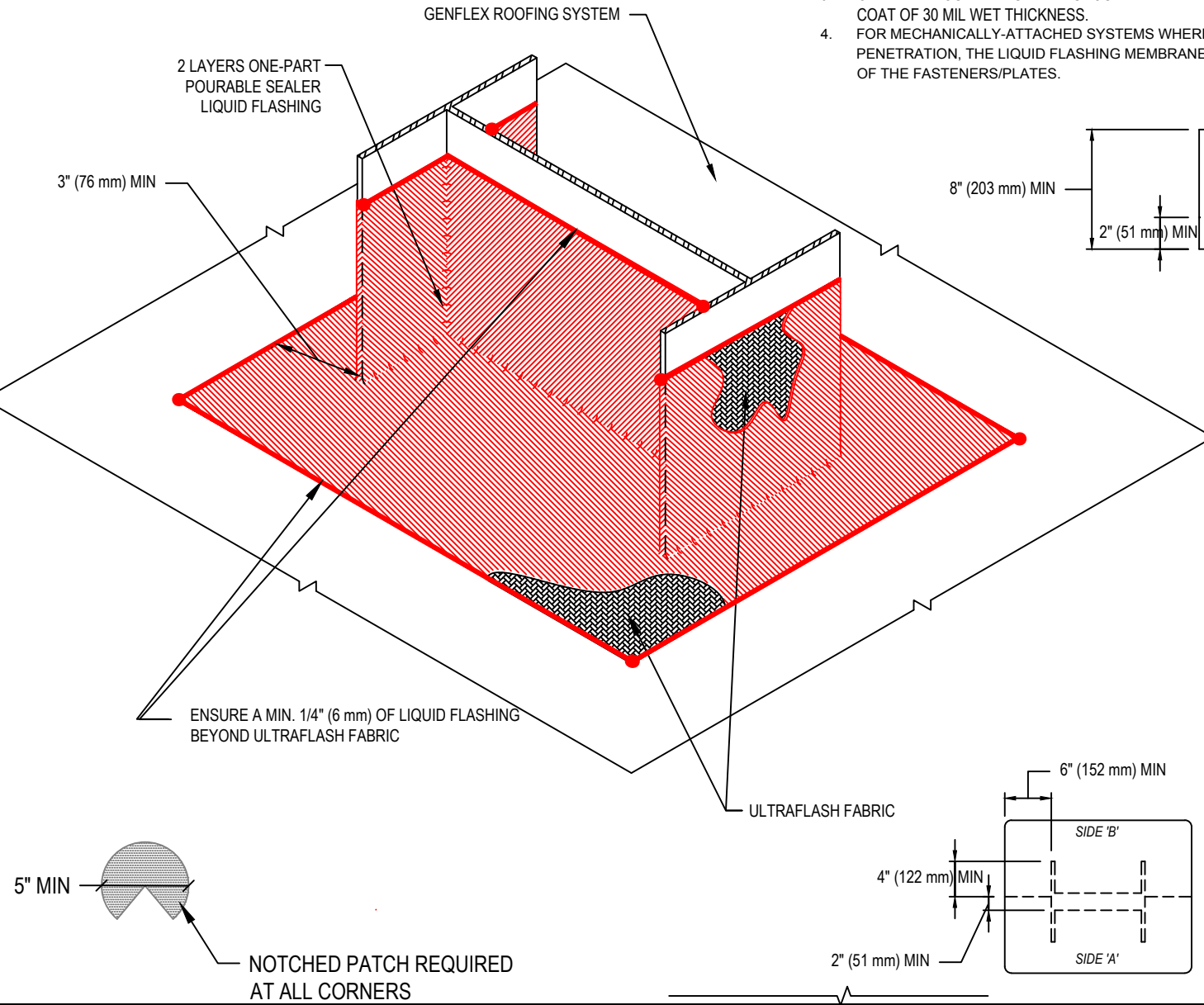

ULTRAFLASH FABRIC

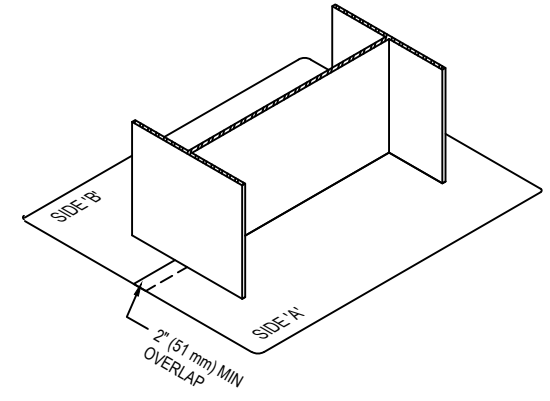
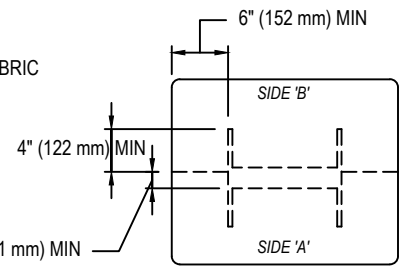
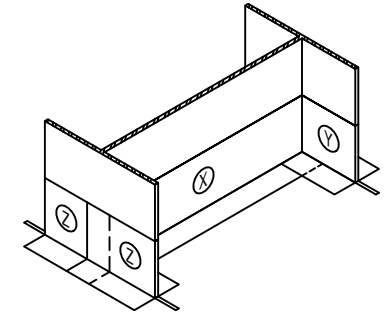
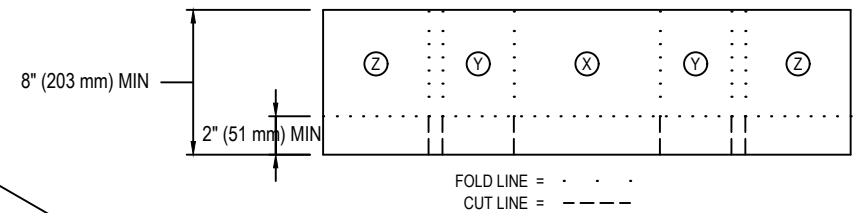

**ONE-PART POURABLE SEALER  
I-BEAM FLASHING**

**GENFLEX™**

ACCEPTABLE SYSTEMS: **TPO, EPDM**

MAXIMUM WARRANTY: 20 Years

ISSUE / REVISION DATE:  
**08/15/2019**

DETAIL NO.  
**PS-P-2**