

NOTE:

1. REFER TO GENFLEX WEBSITE FOR MOST CURRENT INFORMATION.
2. WOOD NAILER MUST BE INSTALLED TO MEET APPLICABLE BUILDING CODES OR 200 lb PER LINEAR FOOT MINIMUM IN ANY GIVEN DIRECTION.

TIE-IN TO EXISTING ROOF SYSTEM NOT WARRANTED BY GENFLEX.

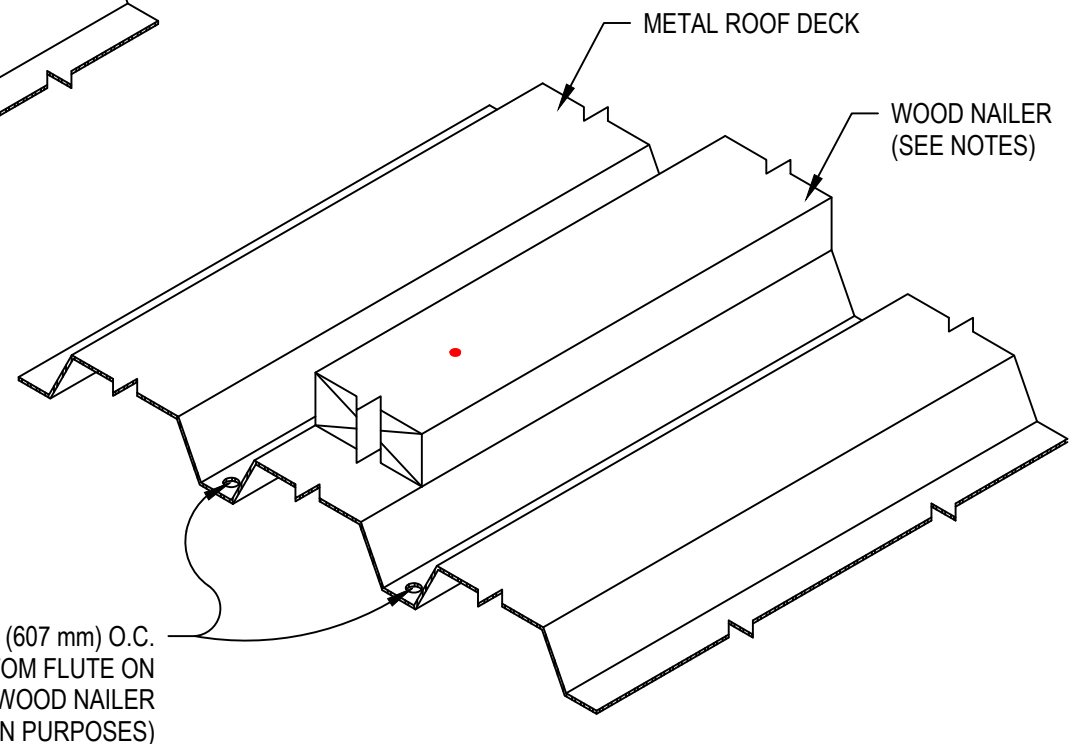
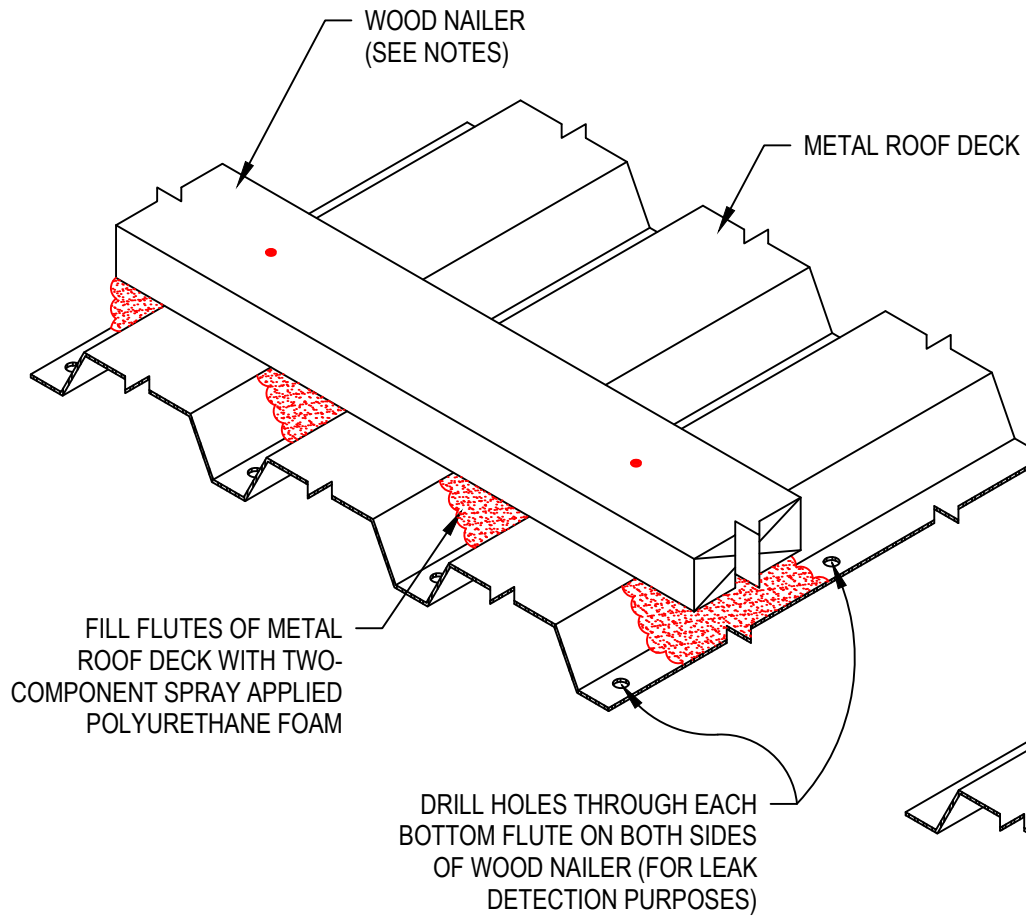

REFER TO S2S-BT-19 OR S2S-BT-21 FOR ADDITIONAL SYSTEM TIE-IN INFORMATION



TIE-IN WITH METAL ROOF DECK

GENFLEX™

ACCEPTABLE SYSTEMS: **SEAM2SEAM™ EPDM**

GENFLEX: (800) 443-4272 www.genflex.com

MAXIMUM WARRANTY: 20 Years

ISSUE / REVISION DATE:

04/06/2020

NOT TO SCALE

DETAIL NO.

S2S-BT-24