

- NOTE:
1. REFER TO GENFLEX WEBSITE FOR MOST CURRENT INFORMATION.
  2. COMPRESSIBLE TUBE (SUPPLIED BY OTHERS) DIAMETER MUST EXCEED THE DECK OPENING BY 50% MIN. OR DESIGNED MOVEMENT (WHICH EVER IS GREATER).
  3. INSTALL SACRIFICIAL EPDM MEMBRANE LAYER AGAINST SEAM2SEAM EPDM TO PREVENT ADHESION TO COMPRESSIBLE TUBE.
  4. BATTEN STRIPS MAY BE USED IN LIEU OF 2" METAL PLATES. REFER TO "BT" DETAILS FOR SPECIFIC BASE TIE-IN INFORMATION, REQUIREMENTS AND OPTIONS.
  5. WOOD NAILER MUST BE INSTALLED TO MEET APPLICABLE BUILDING CODES OR 200 lb PER FOOT MINIMUM IN ANY GIVEN DIRECTION.

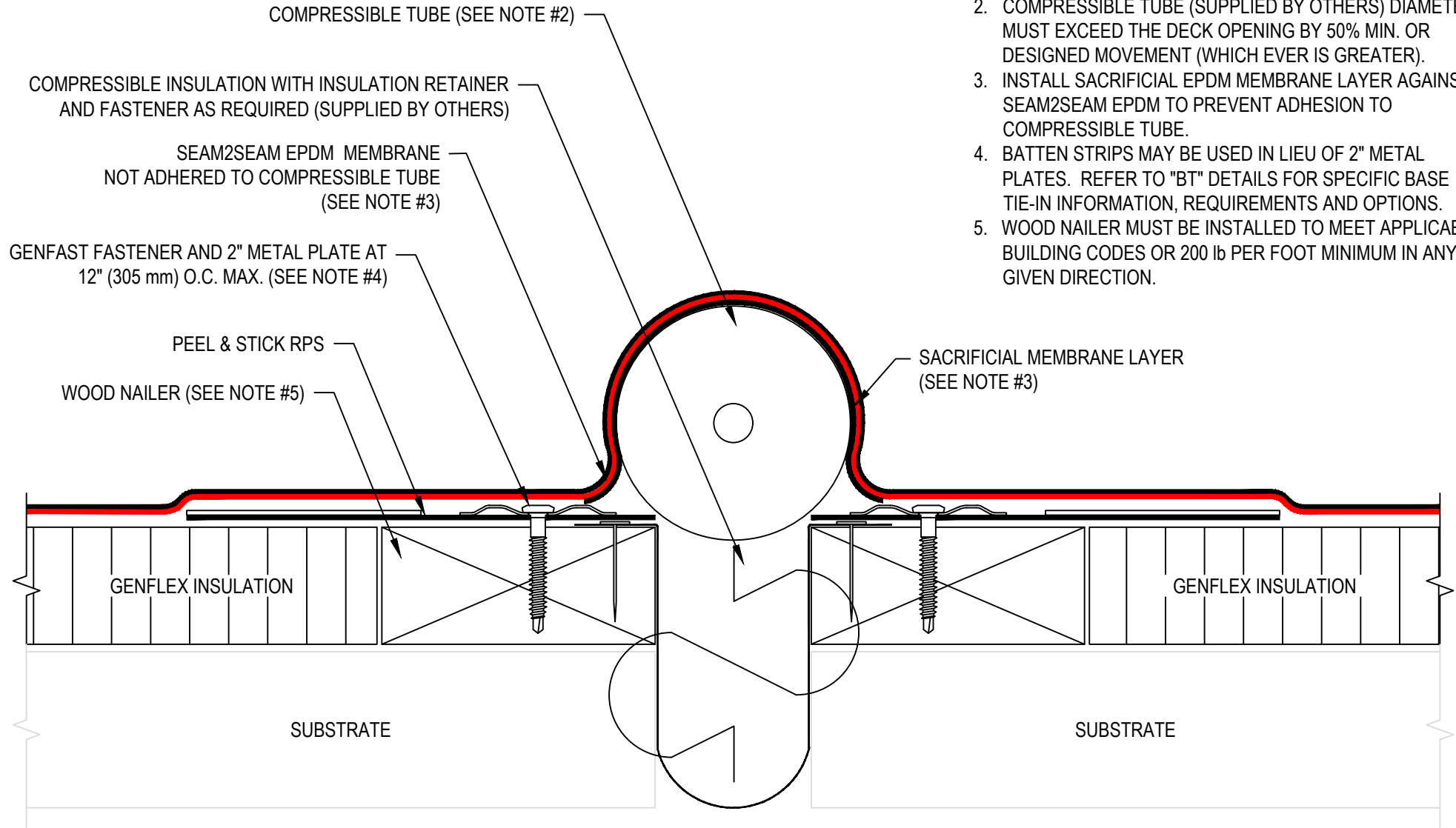

**EXPANSION JOINT (FIELD FABRICATED) W/ PEEL & STICK RPS AND WOOD NAILER - ROOF TO ROOF**

**GENFLEX™**

ACCEPTABLE SYSTEMS: **SEAM2SEAM™ EPDM**

MAXIMUM WARRANTY: 20 Years

ISSUE / REVISION DATE:

04/06/2020

DETAIL NO.

**S2S-E-3**

GENFLEX: (800) 443-4272 www.genflex.com

NOT TO SCALE