

NOTE:

1. REFER TO THE GENFLEX™ WEBSITE FOR MOST CURRENT INFORMATION.
2. WOOD NAILER MUST BE INSTALLED TO MEET APPLICABLE BUILDING CODES.
3. CONTINUOUS BEAD OF WATER STOP REQUIRED UNDER NAILER AT FASTENER LOCATIONS.

**REFER TO EZT-BT-19,
EZT-BT-21, OR EZT-BT-23
FOR ADDITIONAL SYSTEM
TIE-IN INFORMATION**

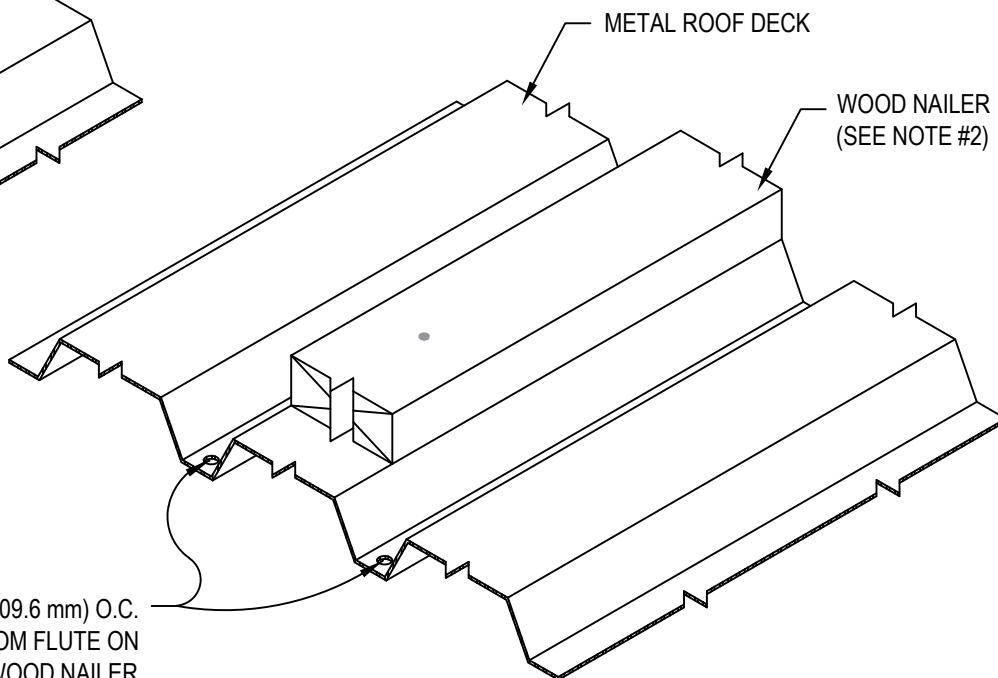
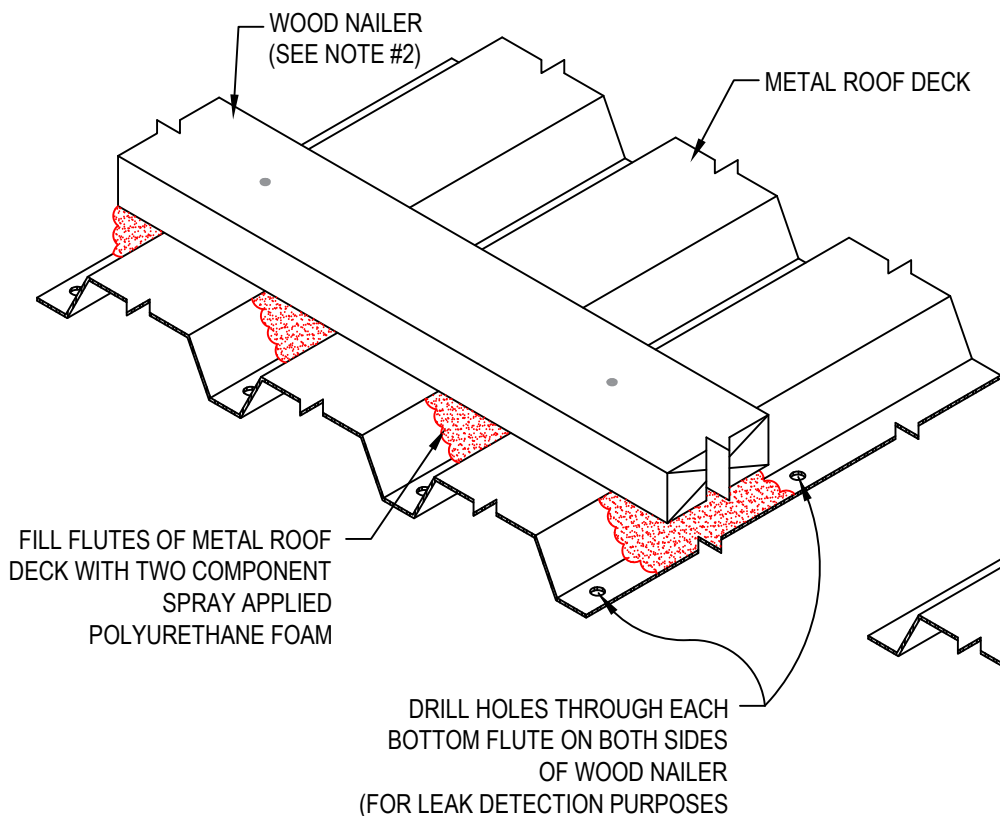

DRILL HOLES 24" (609.6 mm) O.C. THROUGH EACH BOTTOM FLUTE ON BOTH SIDES OF WOOD NAILER (FOR LEAK DETECTION PURPOSES).

WARRANTY MEMBRANE REQUIREMENTS:

15-YEAR
TPO - 45 MIL
20-YEAR
TPO - 60 MIL

TIE-IN TO EXISTING ROOF SYSTEMS NOT WARRANTED BY GENFLEX



TIE-IN EZ TPO WITH METAL ROOF DECK

MATERIAL: EZ TPO

ACCEPTABLE SYSTEMS: ALL

MAXIMUM WARRANTY: 20 Years

ISSUE / REVISION DATE:

10/23/25

DETAIL NO.

EZT-BT-24

NOT TO SCALE

GENFLEX: (800) 443-4272 www.genflex.com